

ATLAS POOL ENCLOSURE USERS' GUIDE

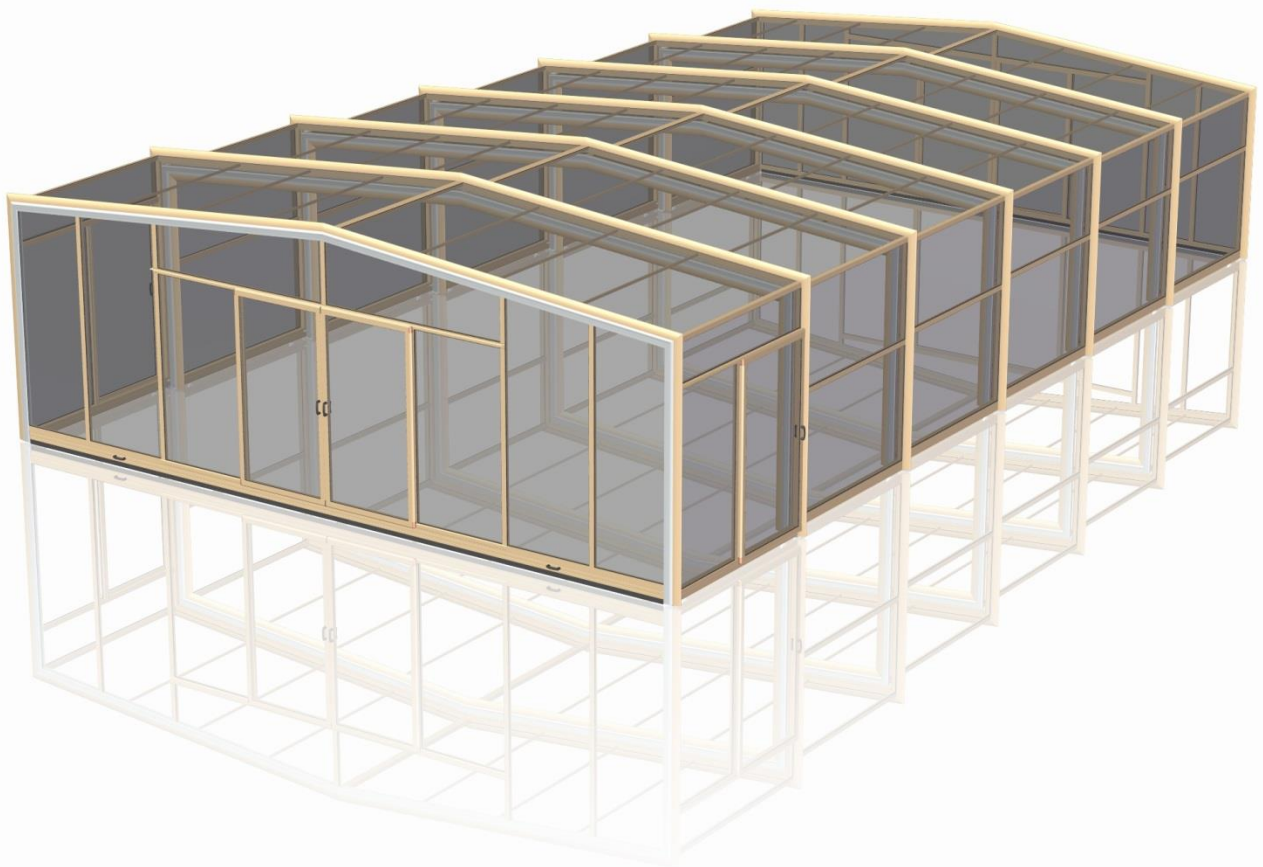

Before using an Atlas enclosure please read the users' guide carefully.

1. Technical features of the enclosure:

Resulting from continuous product development, the enclosures represent the highest quality enclosure available.

The Atlas enclosure is produced using a specially structured aluminum profile system (AW6060 T6), stainless steel (1.4301) fasteners and fittings.

The shape of an Atlas enclosure is defined by its vertical side walls and roof sloped at 5 degrees. Each segment rolls on 4 wheels on the surrounding surface. Each segment rolls telescopically into the next segment and is secured with a special guide module that slides inside a groove.

The vertical walls and end walls of the enclosure feature 4 mm polycarbonate glazing with rubber seals on both sides. The roof of the enclosure is glazed with double wall polycarbonate panes that are supported by extrusions from below and are insulated with rubber seals from above.

An Atlas enclosure contains 2200 mm long segments. The maximum width of the segments is 9600 mm. In case of an enclosure opening to one end, 6 – 7 segments are recommended. If additional segments are required, we recommend configuring the enclosure to open to both ends.

The segments are secured to the ground with strong 5 mm thick stainless steel (1.4301) tabs, glued anchors and lockable M8 threaded bolts. Depending on the model, the enclosure is moved by either manual or motorized effort.

A rubber seal at the edges of the segments provides dust and heat insulation. The joints of the load bearing structure are reinforced with alloy aluminum fasteners. The structural elements are joined with chrome steel joints. A stainless steel brush strip provides insulation between the enclosure and the ground.

ATTENTION: Atlas enclosures do not create an airtight seal when closed, so they are not economical to heat and use in wintertime. An essential condition for optimum performance is a proper slope and a smooth rolling surface. The slope direction should be outwards from the pool to a maximum of 20 mm/m. Any surface unevenness can be a maximum of 10 mm/m.

2. Precautions to follow while in use

2.1. Moving

Before moving the enclosure, remove the securing bolts of all but the very last segment. The largest segment has 4, the others have 2 bolts mounting them to the ground. On each segment one of the bolts is secured with a key therefore those can only be removed after placing the key into the groove.

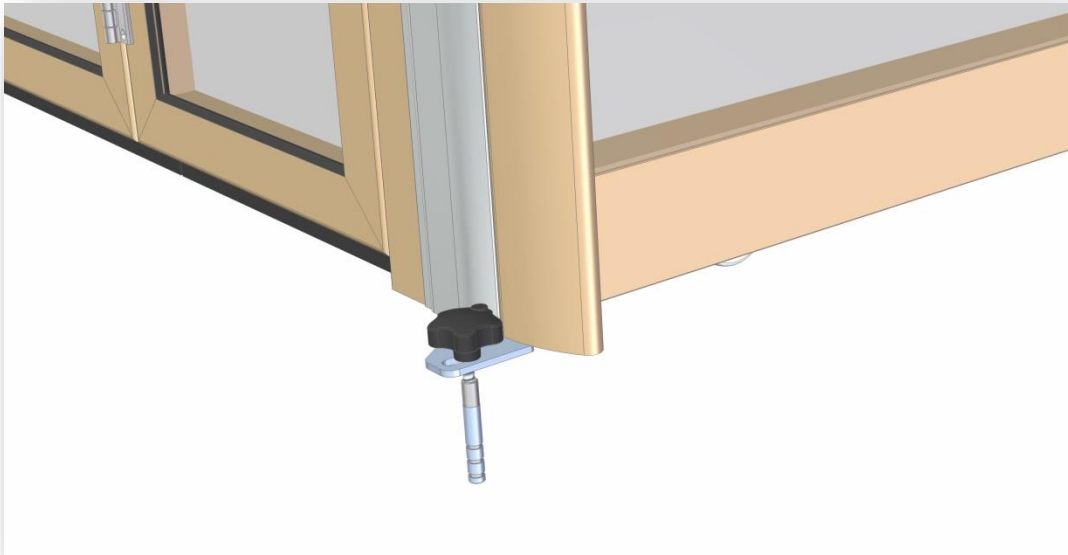

Before moving the enclosure pull up the front wall latches, fold up the sill and the front wall or open up both sides of the accordion door.

ATTENTION: Serious damage can occur if the unlocked front wall is moved either manually or by the motor; therefore unlocking the bolts requires special attention.

- **Moving manually (model without the motor)**

After removing all the bolts the enclosure can be rolled off the pool. Lower and smaller span enclosures can be moved by pushing on one side, but for spans wider than 5 m we recommend moving both sides at the same time.

- **Motorized movement**

After removing all the bolts the enclosure can be moved using the motor. Read the guidelines in the user manual for instructions on how to move the enclosure using the motor unit.

The motorized movement does not have power limitations or sensors. Monitor the segments' movement to avoid crashing into objects or people. In case of any abnormality or accident stop the motor immediately. There should not be any obstacles blocking the path of the enclosure. Crashing into any objects can lead to the damage of the enclosure.

3. Locking the enclosure

Move the segments manually or by a motor above the anchors that are placed in the ground. Secure them to the ground using bolts.

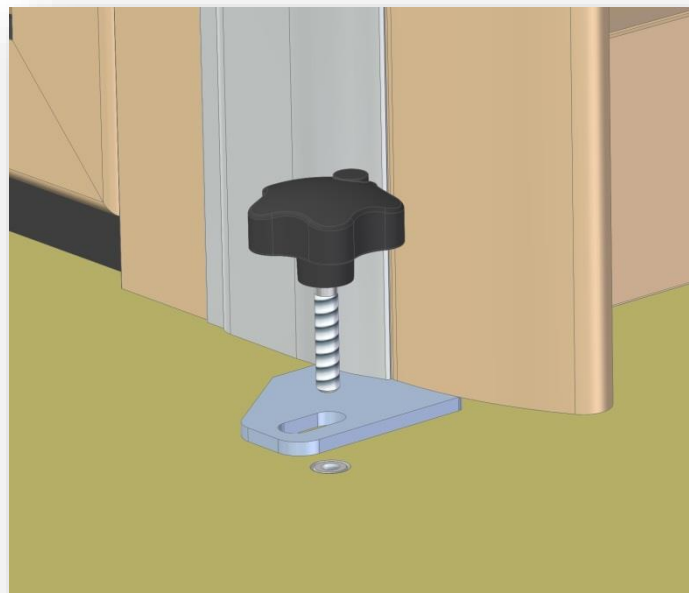

During manual moving pay attention to achieve parallel movement. In case of divergence correct the direction. (The most practical way of directing the enclosure is to follow the straight line of the tile grouting or the pool edge.) If you notice any deviation at the segment anchor point, pull the segments to the anchor point by hand then secure them with the bolts.

Monitor the movement of the segments while moving the enclosure via motor. In case of any deviation of the linear movement, adjust it by pressing the appropriate buttons on the remote control. *Please find detailed instructions in the motor control unit user manual.*

4. Front and back walls

4.1 Accordion door on the back wall

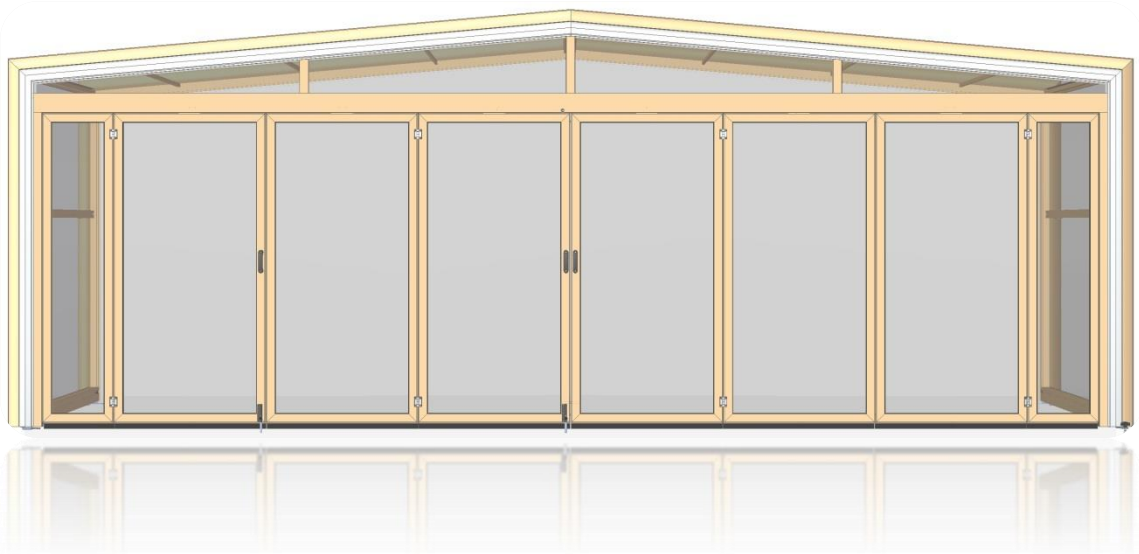

Opening and closing the accordion door requires little effort when done properly.

Opening or closing the accordion doors too forcefully or quickly can cause tension in the door sections that may lead to structural damage.

Turn the key in the square lock to unlock the accordion door then pull up the latches securing the door sections. Move the doors to the open position with a little effort. Repeat the steps on the opposite side as well.

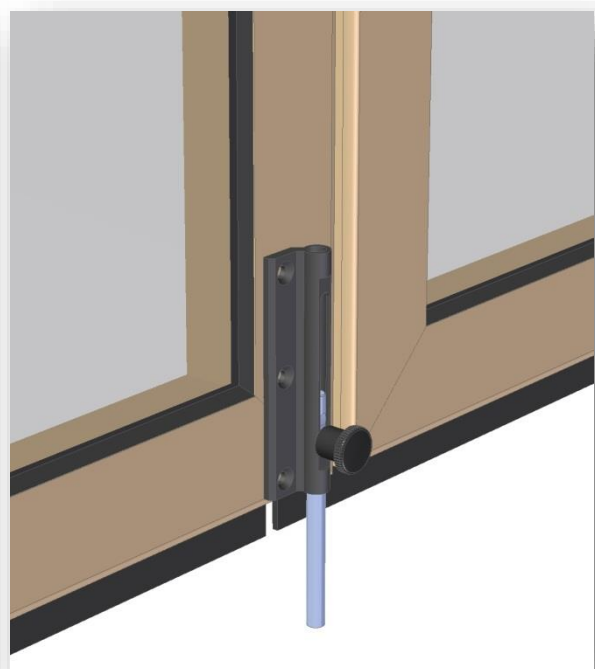
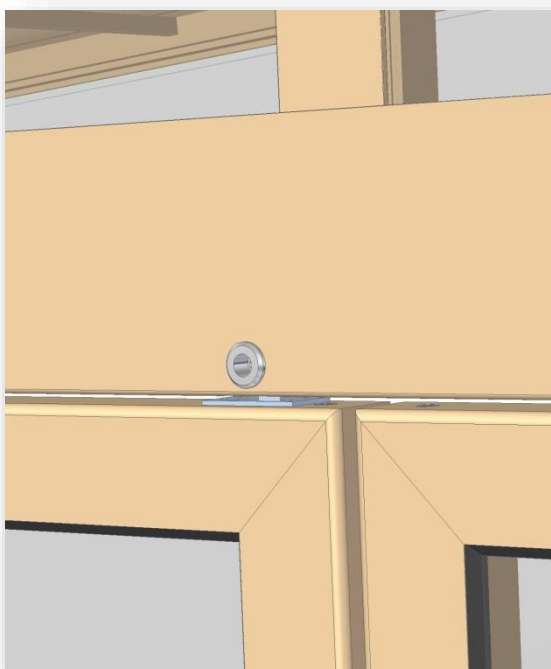

The enclosures can only be moved when the accordion doors are open on the end walls. Moving the enclosure with closed doors may damage the end wall.

Pull the door sections with a little manual effort to close the accordion door into a closed position. Repeat the steps on the opposite side then lock the doors with the square lock. Secure both door sections to the ground with the latches.

4.2 Flap end wall

Turn the key in the square lock on both sides then open up the flap at the bottom of the end wall. Secure it in its raised position with the spring-loaded securing pin.

ATTENTION: When unlocking the spring-loaded securing pin the flap will fall down, due to its weight, so precautions must be taken to avoid any accidents.

4.3 Sliding door and fixed end wall

The use of a sliding door and a fixed end wall model does not require any special explanation. Before moving the front wall and the segment with the end wall make sure that the latches are unlocked. Moving the enclosure with locked latches may lead to the damage of the end wall. (point no. 2)

5. Storm protection

The structural strength is measured with the enclosure in its closed position. During summer, wind load is the most significant, while in winter, snow and wind load occur together.

Regarding storm protection, the following points should to be considered:

- The enclosure must be in a closed position and segments must be anchored to the ground according to point 3.
- An open enclosure must not be left unattended. The structure's aerodynamics change in an open position and is significantly more fragile when open than when closed.
- Both sliding and hinged doors must be locked when the enclosure is not in use and the keys must be removed from the locks. End walls must be secured with latches as well.

Snow protection

- The enclosure must be anchored to the ground in case of snow or wind load.
- In case of heavy snow, the snow must be cleared off the enclosure or a 12°C interior temperature must be ensured so the snow continuously melts off the enclosure.

6. Cleaning and maintenance

- The enclosure does not require any special maintenance.
- Clean warm water is the most appropriate for cleaning the aluminum structure and the glazing. In case of serious dirtiness use a wet sponge and diluted detergent. Avoid stronger bases or household abrasives.
- Never scrub or rub the glazing.
- Never use dry sponges or wipes.
- Condensation may occasionally appear in the cells. This is natural, and will disappear after a prolonged dry period.